

Classic



A proven success time and again



This showcase has the warmth and feel of a relaxed atmosphere, comes in many height configurations including a top square glass option. Lift up hydraulic front glass with Pyrolytic heat on front and sides, available in Pastry, Gelato and Chocolate applications. Gelato and Ice Cream showcases have pans storage capability. Just like the entire OscarTek™ line it can be customized to fit any décor. LED lighting is standard.



Discover the Art of Display...

Classic Photos



361-367 Beach Road, Burlingame, CA 94010
Tel: 855.885.2400 | 650.342.2400 | Fax: 650.342.7400
sales@oscartek.com | www.oscartek.com

CLASSIC

Gelato Showcase

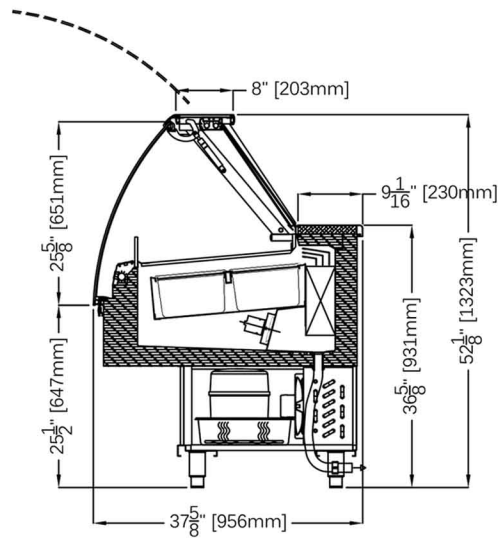

STANDARD FEATURES

- Stainless steel insulated body with tubular painted galvanized chassis
- Silver trim finish
- Dixell digital controller
- Air cooled condensing unit
- Temperature front and side glass single pane with anti-fog serigraph
- Lift up hydraulic front glass
- LED lighting
- Temperd glass shelves when applicable
- Plexiglass sliding doors
- Stainless steel work bench
- Cases ship standard unfinished front and stainless steel skin sides

OPTIONS

- Champagne trim finish
- Stainless steel inserts and pans
- Dip well
- Cone holder
- Frozen cake stainless steel trays
- Dual temperature zone
- Marble/granite work counter
- RAL color finish/wood laminate
- Roll down curtain
- Remote/water cooled unit
- Matching front cabinetry counters with top glass
- Casters

CLASSIC GELATO					
TECHNICAL FEATURES		MODELS			
		CLASSIC CG1000	CLASSIC CG1500	CLASSIC CG2000	CLASSIC CG2000DT
External Dimensions (L-D-H)	Inches	39 1/2" - 37 3/4" - 52 1/8"	59 1/8" - 37 3/4" - 52 1/8"	78 3/4" - 37 3/4" - 52 1/8"	78 3/4" - 37 3/4" - 52 1/8"
	Inches-MM	1000 - 956 - 1323	1500 - 956 - 1323	2000 - 956 - 1323	2000 - 956 - 1323
Crated Dimensions (L-D-H)	Inches	44" - 42 1/2" - 57"	65" - 42 1/4" - 57"	84 3/4" - 42 1/4" - 57"	84 3/4" - 42 1/4" - 57"
	Inches-MM	1100 - 1056 - 1447	1600 - 1056 - 1447	2100 - 1056 - 1447	2100 - 1056 - 1447
4 Liter Pan Capacity* 10 1/8" x 6 1/8" x 5 7/8" (258mm x 156mm x 150mm)	Pan Configuration				
5 Liter Pan Capacity* 14 3/16" x 6 1/2" x 4 3/4" (360mm x 165mm x 120mm)	Pan Configuration				
Refrigeration	Type	Fan Ventilated	Fan Ventilated	Fan Ventilated	Fan Ventilated
Operating Temperature	°C / °F	-18°C / -0.4°F	-18°C / -0.4°F	-18°C / -0.4°F	(2) -18°C / -0.4°F
Compressor	Nr./Type	1 / Hermetic	1 / Hermetic	1 / Hermetic	2 / Hermetic
BTU'S @ -25°F Evap Temperature	BTU'S	2450 BTU'S	3580 BTU'S	4550 BTU'S	1984 BTU'S
		400/3/50 (EU)	400/3/50 (EU)	400/3/50 (EU)	400/3/50 (EU)
Electric Supply	(V/Ph/Hz)	208-220/1/60 (USA)	208-220/1/60 (USA)	208-220/1/60 (USA)	208-220/1/60 (USA)
Power Consumption	(W/A)	1950W / 5A	3200W / 5A	3800W / 9A	5000W / 12A
Defrost	Mode/Type	Reverse Cycle	Reverse Cycle	Reverse Cycle	Reverse Cycle
Climatic Class	R.	4/30/86/55%	4/30/86/55%	4/30/86/55%	4/30/86/55%
Refrigerant Gas	Type	R404A	R404A	R404A	R404A
Net Weights	Kg/Lb	190Kgs / 418Lbs	230Kgs / 507Lbs	270Kgs / 595Lbs	300Kgs / 661Lbs
Crated Weights	Kg/Lb	290Kgs / 639Lbs	360Kgs / 793Lbs	425Kgs / 936Lbs	455Kgs / 1003Lbs

* DIMENSIONS ARE WITHOUT SIDE PANELS * PANS NOT INCLUDED

* Manufacturer reserves the right to change specifications without notice. Not responsible for error and omissions.



361-367 Beach Road, Burlingame, CA 94010
 Tel: 855.885.2400 | 650.342.2400 | Fax: 650.342.7400
 sales@oscartek.com | www.oscartek.com



CLASSIC

Deli/Pastry Showcase

DELI/PASTRY WITHOUT DRAWERS

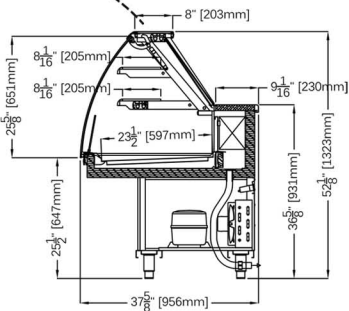

DELI/PASTRY WITH DRAWERS

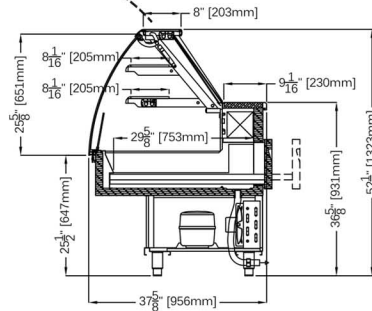

OPTIONAL: COLD STORAGE

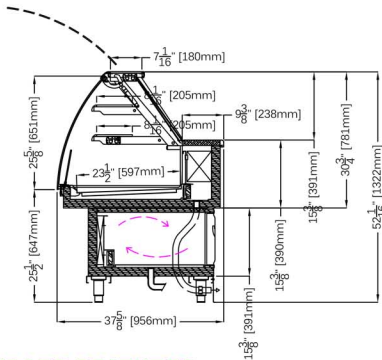

FULLY REFRIGERATED AVAILABLE IN LINEAR MODELS ONLY (PULL OUT DRAWERS NOT AVAILABLE)

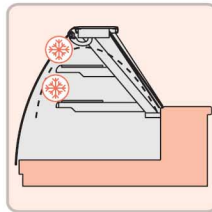

STANDARD FEATURES

- Stainless steel insulated body with tubular painted galvanized chassis
- Silver trim finish
- Non-refrigerated shelves
- Dixell digital controller
- Air cooled condensing unit
- Temperature front and side glass single pane with anti-fog serigraph
- Lift up hydraulic front glass
- LED lighting
- Plexiglass sliding doors
- Stainless steel work bench
- Pastry with drawer (static refrigeration)
- Cases ship standard unfinished front and stainless steel skin sides

OPTIONS

- Fully refrigerated shelves (linear models only)
- Marble/Granite work counter
- RAL color finish/wood laminate
- Champagne trim finish
- Roll down curtain
- Remote/water cooled unit
- Matching front cabinetry counters with top glass
- Stainless steel step up deck shelf
- Cold storage option with static refrigeration and separate control
- Casters



Photo shown is with optional front finish and champagne trim finish. Standard cases are silver trim finish, unfinished front, and stainless steel skin sides

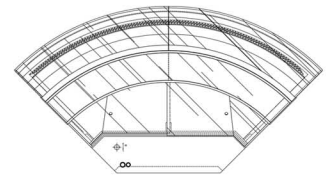

90° Open Corner

CLASSIC DELI/PASTRY							
TECHNICAL FEATURES		MODELS					
		CLASSIC CDP1000	CLASSIC CDP1500	CLASSIC CDP2000	CLASSIC CDP2500	CLASSIC CDP3000	CLASSIC CDPA90
External Dimensions (L-D-H)	Inches	39 1/2" - 37 3/4" - 52 1/8"	59 1/8" - 37 3/4" - 52 1/8"	78 3/4" - 37 3/4" - 52 1/8"	98 1/2" - 37 3/4" - 52 1/8"	118 1/4" - 37 3/4" - 52 1/8"	80 1/16" - 37 3/4" - 52 1/8"
	Inches-MM	1000 - 956 - 1323	1500 - 956 - 1323	2000 - 956 - 1323	2500 - 956 - 1323	3000 - 956 - 1323	2034 - 956 - 1323
Crated Dimensions (L-D-H)	Inches	44" - 42 1/2" - 57"	65" - 42 1/4" - 57"	84 3/4" - 42 1/4" - 57"	102 3/4" - 42 1/4" - 57"	122 3/4" - 42 1/4" - 57"	86" - 42 1/4" - 57"
	Inches-MM	1100 - 1056 - 1447	1600 - 1056 - 1447	2100 - 1056 - 1447	2600 - 1056 - 1447	3100 - 1056 - 1447	2184 - 1056 - 1447
Power Supply	(V)	120V	120V	120V	120V	120V	120V
BTU'S @ +14°F Evap							
Temperature	BTU'S	1600 BTU'S	2016 BTU'S	2560 BTU'S	3072 BTU'S	3072 BTU'S	2400 BTU'S
Amperage	(A)	5A	5.5A	8.5A	8.6A	11A	5A
Deck Operating Temperature*	°F	39°F	39°F	39°F	39°F	39°F	39°F
Net Weights	Kg/Lb	147Kgs / 323Lbs	186Kgs / 410Lbs	224Kgs / 492Lbs	271Kgs / 596Lbs	314Kgs / 722Lbs	186Kgs / 410Lbs
Crated Weights	Kg/Lb	157Kgs / 297Lbs	200Kgs / 440Lbs	239Kgs / 526Lbs	291Kgs / 640Lbs	334Kb / 734Lbs	200Kgs / 440Lbs

* Dimensions are without side panels

* Any and all shelves above the deck will NOT be refrigerated on these models

* Manufacturer reserves the right to change specifications without notice. Not responsible for error and omissions.



512 South Airport Blvd., South San Francisco, CA 94080
 Tel: 855.885.2400 | 650.342.2400 | Fax: 650.342.7400
 sales@oscartek.com | www.oscartek.com



CLASSIC

Chocolate Showcase

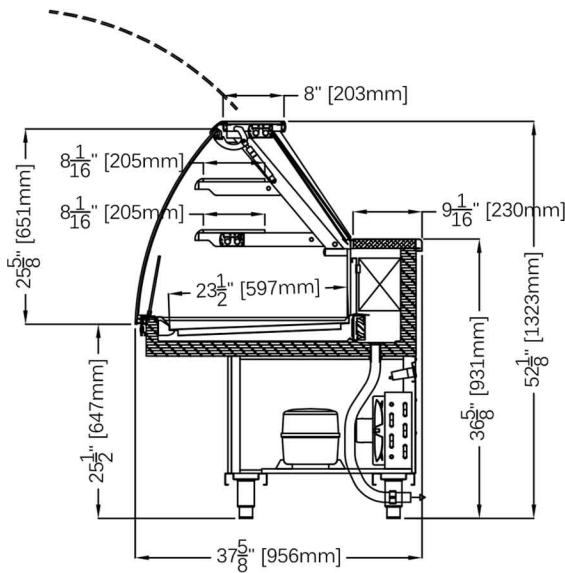

Photo shown is with optional front finish and champagne trim finish. Standard cases are silver trim finish, unfinished front, and stainless steel skin sides

STANDARD FEATURES

- Stainless steel insulated body with tubular painted galvanized chassis
- Silver trim finish
- Dixell digital controller
- Air cooled condensing unit
- Temperature front and side glass single pane with anti-fog serigraph
- Lift up hydraulic front glass
- LED lighting
- Plexiglass sliding doors
- Stainless steel work bench
- Humidity control system
- Cases ship standard unfinished front and stainless steel skin sides

OPTIONS

- Marble/Granite work counter
- RAL color finish/wood laminate
- Champagne trim finish
- Roll down curtain
- Remote/water cooled unit
- Matching front cabinetry counters with top glass
- Stainless steel step up deck shelf
- Cold storage option with static refrigeration and separate control
- Casters

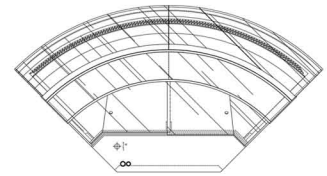

90° Open Corner

CLASSIC CHOCOLATE							
TECHNICAL FEATURES		MODELS					
		CLASSIC CC1000	CLASSIC CC1500	CLASSIC CC2000	CLASSIC CC2500	CLASSIC CC3000	CLASSIC CCA90
External Dimensions (L-D-H)	Inches	39 1/2" - 37 3/4" - 52 1/8"	59 1/8" - 37 3/4" - 52 1/8"	78 3/4" - 37 3/4" - 52 1/8"	98 1/2" - 37 3/4" - 52 1/8"	118 1/4" - 37 3/4" - 52 1/8"	80 1/16" - 37 3/4" - 52 1/8"
	MM	1000 - 956 - 1323	1500 - 956 - 1323	2000 - 956 - 1323	2500 - 956 - 1323	3000 - 956 - 1323	2034 - 956 - 1323
Crated Dimensions (L-D-H)	Inches	44" - 42 1/2" - 57"	65" - 42 1/4" - 57"	84 3/4" - 42 1/4" - 57"	102 3/4" - 42 1/4" - 57"	122 3/4" - 42 1/4" - 57"	86" - 42 1/4" - 57"
	MM	1100 - 1056 - 1447	1600 - 1056 - 1447	2100 - 1056 - 1447	2600 - 1056 - 1447	3100 - 1056 - 1447	2184 - 1056 - 1447
Power Supply	(V)	220V	220V	220V	220V	220V	220V
BTU'S @ +35°F Evap Temperature	BTU'S	1600 BTU'S	2016 BTU'S	2560 BTU'S	3072 BTU'S	3072 BTU'S	2400 BTU'S
Amperage	(A)	5A	5.5A	8.5A	8.6A	11A	5A
Humidity Control*	%	35-75%	35-75%	35-75%	35-75%	35-75%	35-75%
Deck Operating Temperature*	°F	57°F	57°F	57°F	57°F	57°F	57°F
Net Weights	Kg/Lb	147Kgs / 323Lbs	186Kgs / 410Lbs	224Kgs / 492Lbs	271Kgs / 596Lbs	314Kgs / 722Lbs	186Kgs / 410Lbs
Crated Weights	Kg/Lb	157Kgs / 297Lbs	200Kgs / 440Lbs	239Kgs / 526Lbs	291Kgs / 640Lbs	334Kgs / 734Lbs	200Kgs / 440Lbs

* Dimensions are without side panels

* Any and all shelves above the deck will NOT be refrigerated on these models

* Manufacturer reserves the right to change specifications without notice. Not responsible for error and omissions.



361-367 Beach Road, Burlingame, CA 94010
 Tel: 855.885.2400 | 650.342.2400 | Fax: 650.342.7400
 sales@oscartek.com | www.oscartek.com



CLASSIC

Neutral Showcase

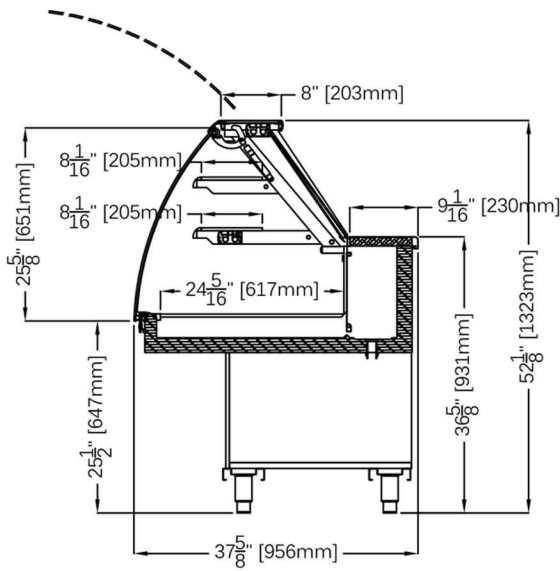

Photo shown is with optional front finish and champagne trim finish. Standard cases are silver trim finish, unfinished front, and stainless steel skin sides



STANDARD FEATURES

- Stainless steel insulated body with tubular painted galvanized chassis
- Silver trim finish
- Lift up hydraulic front glass
- LED lighting
- Plexiglass sliding doors
- Stainless steel work bench
- Cases ship standard unfinished front and stainless steel skin sides

OPTIONS

- Marble/Granite work counter
- RAL color finish/wood laminate
- Champagne trim finish
- Matching front cabinetry counters with top glass
- Heated glass shelf with electronic control
- Casters

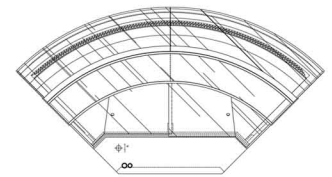

90° Open Corner

CLASSIC NEUTRAL							
TECHNICAL FEATURES		MODELS					
		CLASSIC CN1000	CLASSIC CN1500	CLASSIC CN2000	CLASSIC CN2500	CLASSIC CN3000	CLASSIC CNA90
External Dimensions (L-D-H)	Inches	39 1/2" - 37 3/4" - 52 1/8"	59 1/8" - 37 3/4" - 52 1/8"	78 3/4" - 37 3/4" - 52 1/8"	98 1/2" - 37 3/4" - 52 1/8"	118 1/4" - 37 3/4" - 52 1/8"	80 1/16" - 37 3/4" - 52 1/8"
	MM	1000 - 956 - 1323	1500 - 956 - 1323	2000 - 956 - 1323	2500 - 956 - 1323	3000 - 956 - 1323	2034 - 956 - 1323
Crated Dimensions (L-D-H)	Inches	44" - 42 1/2" - 57"	65" - 42 1/4" - 57"	84 3/4" - 42 1/4" - 57"	102 3/4" - 42 1/4" - 57"	122 3/4" - 42 1/4" - 57"	86" - 42 1/4" - 57"
	MM	1100 - 1056 - 1447	1600 - 1056 - 1447	2100 - 1056 - 1447	2600 - 1056 - 1447	3100 - 1056 - 1447	2184 - 1056 - 1447
Power Supply	(V)	120V	120V	120V	120V	120V	120V
Amperage	(A)	3A	4A	4.5A	5A	5.5A	4A
Operating Temperature	°F	Ambient	Ambient	Ambient	Ambient	Ambient	Ambient
Net Weights	Kg/Lb	130Kgs / 286Lbs	170Kgs / 374Lbs	210Kgs / 462Lbs	245Kgs / 539Lbs	285Kgs / 627Lbs	170Kgs / 374Lbs
Crated Weights	Kg/Lb	150Kgs / 297Lbs	190Kgs / 418Lbs	230Kgs / 506Lbs	271Kgs / 596Lbs	310Kgs / 682Lbs	190Kgs / 418Lbs

* DIMENSIONS ARE WITHOUT SIDE PANELS

* Manufacturer reserves the right to change specifications without notice. Not responsible for error and omissions.



361-367 Beach Road, Burlingame, CA 94010
 Tel: 855.885.2400 | 650.342.2400 | Fax: 650.342.7400
 sales@oscartek.com | www.oscartek.com



CLASSIC

Hot Showcase

CS (DRY)

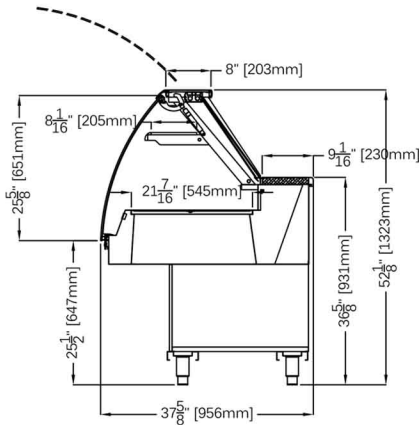

CBM (BAIN MARIE)

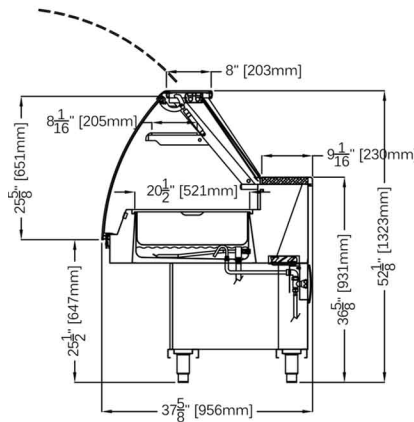

STANDARD FEATURES

- Stainless steel insulated body with tubular painted galvanized chassis
- Silver trim finish
- Lift up hydraulic front glass
- LED lighting
- Plexiglass sliding doors
- Stainless steel work bench
- CS: dry warm top on stainless steel basin
- CBM: hot well food warmer
- CBM: each well has its own individual control to regulate the temperature
- Cases ship standard unfinished front and stainless steel skin sides

OPTIONS

- Champagne trim finish
- Stainless steel insert
- Marble/Granite work counter
- RAL color finish/wood laminate
- Matching front cabinetry counters with top glass
- Heated glass shelf with electronic control
- Casters

CBM (BAIN MARIE): SHOWN WITH AUTO-FILL

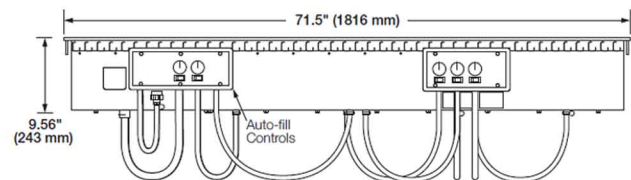
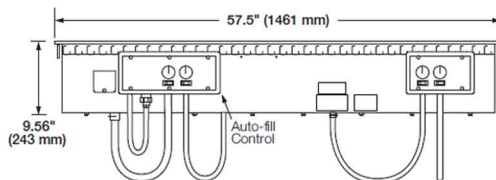
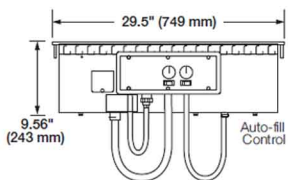

* Manufacturer reserves the right to change specifications without notice. Not responsible for error and omissions.



361-367 Beach Road, Burlingame, CA 94010
 Tel: 855.885.2400 | 650.342.2400 | Fax: 650.342.7400
 sales@oscartek.com | www.oscartek.com



CLASSIC HOT (CS - DRY)				
TECHNICAL FEATURES		MODELS		
		CLASSIC CCS1000	CLASSIC CCS1500	CLASSIC CCS2000
External Dimensions (L-D-H)	Inches	39 1/2" - 37 3/4" - 52 1/8"	59 1/8" - 37 3/4" - 52 1/8"	78 3/4" - 37 3/4" - 52 1/8"
	MM	1000 - 956 - 1323	1500 - 956 - 1323	2000 - 956 - 1323
Crated Dimensions (L-D-H)	Inches	44" - 42 1/2" - 57"	65" - 42 1/4" - 57"	84 3/4" - 42 1/4" - 57"
	MM	1100 - 1056 - 1447	1600 - 1056 - 1447	2100 - 1056 - 1447
Power Supply	(V)	220V	220V	220V
Power Consumption	(W)	1550W	2070W	3080W
Operating Temperature	°C / °F	80°C / 177°F	80°C / 177°F	80°C / 177°F
Net Weights	Kg/Lb	155Kgs / 241Lbs	206Kgs / 453Lbs	257Kgs / 565Lbs
Crated Weights	Kg/Lb	170Kgs / 374Lbs	226Kgs / 497Lbs	283Kgs / 622Lbs

NOTE: DIMENSIONS ARE WITHOUT SIDE PANELS

CLASSIC HOT (CBM - BAIN MARIE)				
TECHNICAL FEATURES		MODELS		
		CLASSIC CCBM1000	CLASSIC CCBM1500	CLASSIC CCBM2000
External Dimensions (L-D-H)	Inches	39 1/2" - 37 3/4" - 52 1/8"	59 1/8" - 37 3/4" - 52 1/8"	78 3/4" - 37 3/4" - 52 1/8"
	MM	1000 - 956 - 1323	1500 - 956 - 1323	2000 - 956 - 1323
Crated Dimensions (L-D-H)	Inches	44" - 42 1/2" - 57"	65" - 42 1/4" - 57"	84 3/4" - 42 1/4" - 57"
	MM	1100 - 1056 - 1447	1600 - 1056 - 1447	2100 - 1056 - 1447
Number of Wells (CBM) *	#	2	4	5
Power Supply **	(V/A)	208-220V / 12A	208-220V / 23A	208-220V / 29A
Power Consumption	(W)	2400W	4850W	6020W
Drain	--	3/4" Drain / 1" Manifold	3/4" Drain / 1" Manifold	3/4" Drain / 1" Manifold
Water Supply ***	--	1/4"	1/4"	1/4"
Net Weights	Kg/Lb	155Kgs / 241Lbs	206Kgs / 453Lbs	257Kgs / 565Lbs
Crated Weights	Kg/Lb	170Kgs / 374Lbs	226Kgs / 497Lbs	283Kgs / 622Lbs

NOTE: DIMENSIONS ARE WITHOUT SIDE PANELS * FLOOR SINK IS REQUIRED FOR WET APPLICATION

**** AVAILABLE IN 3 PHASE CONFIGURATION**

***** AUTO FILL OPTION**

* Manufacturer reserves the right to change specifications without notice. Not responsible for error and omissions.



361-367 Beach Road, Burlingame, CA 94010
 Tel: 855.885.2400 | 650.342.2400 | Fax: 650.342.7400
 sales@oscartek.com | www.oscartek.com



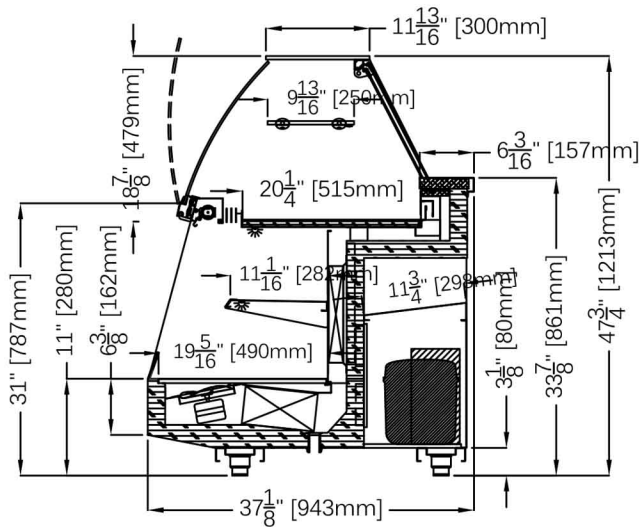

STANDARD FEATURES

- Similar side profile with Classic & Classic II line
- LED lighting top canopy & top shelf
- LED lighting on lower canopy & intermediate shelf
- Tilt back front glass
- Hermetic air cooled condensing unit
- Forced air refrigeration
- Refrigerated deck
- Front, top and side double glasses
- Adjustable legs
- Dixell control with diagnostic
- Cases ship standard unfinished front and stainless steel skin sides

OPTIONS

- Non-refrigerated top
- Self-rolling night curtain
- Condensate water tray with automatic evaporating system
- S/s steps for display area
- Hot glass shelves with electric control
- Remote condensing unit
- RAL color/laminate front and sides
- Casters

CLASSIC & CLASSIC II COMBI			
TECHNICAL FEATURES		MODELS	
		CCOMBI1150	CCOMBI1650
External Dimensions (L-D-H)	Inches	45 1/4" - 37 1/8" - 47 3/4"	65" - 37 1/8" - 47 3/4"
	MM	1150 - 943 - 1213	1650 - 943 - 1213
Crated Dimensions (L-D-H)	Inches	54" - 46" - 63 1/4"	71" - 46" - 63 1/4"
	MM	1371 - 1092 - 1346	1803 - 1092 - 1346
Top Refrigeration Display Area	Type	Fan Ventilated	Fan Ventilated
Refrigeration Display Area	Type	Deck / Lower Shelf	Deck / Lower Shelf
Open Area & Top Deck			
Operating Temperature	°C / °F	+4°C / 39.2°F	+4°C / 39.2°F
Compressor	Nr./Type	1 / Hermetic	1 / Hermetic
Cooling Power @+10°C/+14°F	(W/BTU'S)	1350W / 4350BTU'S	1680W / 5320BTU'S
Electric Supply	(V/Ph/Hz)	230/1/50 (UE) 220/1/60 (USA)	230/1/50 (UE) 220/1/60 (USA)
Power Consumption	(A)	9A	13A
Defrost	Mode/Type	Electric	Electric
Climatic Class	N°/°C/°F/H.R.	4+/35/95/70%	4+/35/95/70%
Refrigerant Gas	Type	R404A	R404A
Net Weights	Kg/Lb	266Kgs / 586Lbs	350Kgs / 771Lbs
Crated Weights	Kg/Lb	391Kgs / 862Lbs	525Kgs / 1157Lbs

* Dimensions are without side panels

* Manufacturer reserves the right to change specifications without notice. Not responsible for error and omissions.



361-367 Beach Road, Burlingame, CA 94010
 Tel: 855.885.2400 | 650.342.2400 | Fax: 650.342.7400
 sales@oscartek.com | www.oscartek.com



CLASSIC GNG

Grab and Go Showcase

STANDARD FEATURES

- Double panel side glasses
- LED lighting on each shelf
- Dixell digital control
- Self contained
- Remote (model A90X only)
- Stainless steel foam in place bottom and top
- Adjustable feet
- Cases ship standard unfinished front and stainless steel skin sides



OPTIONS

- Model A90X - self contained
- Stainless steel side panels in lieu of glass
- Roll down locking shutter
- Epoxy RAL color interior
- Remote air cooled or water cooled
- RAL color/laminate front and side panels
- Condensate pan
- Casters



CLASSIC GRAB AND GO					
TECHNICAL FEATURES		MODELS			
		CLASSIC GNG 1000	CLASSIC GNG 1300	CLASSIC GNG 1500	CLASSIC GNG 1700
External Dimensions (L-D-H)	Inches	39 3/8" - 37 5/8" - 52 1/16"	51 3/16" - 37 5/8" - 52 1/16"	59 1/16" - 37 5/8" - 52 1/16"	66 15/16" - 37 5/8" - 52 1/16"
	Inches-MM	1000 - 956 - 1322	1300 - 956 - 1322	1500 - 956 - 1322	1700 - 956 - 1322
Crated Dimensions (L-D-H)	Inches	46" - 43" - 60"	57" - 43" - 60"	66" - 43" - 60"	73" - 43" - 60"
	Inches-MM	1168 - 1092 - 1524	1447 - 1092 - 1524	1676 - 1092 - 1524	1854 - 1092 - 1524
BTU's @ +14°F Evap Temperature	BTU'S	4200 BTU'S	6222 BTU'S	6720 BTU'S	7225 BTU'S
Power Supply	(V/Ph/Hz)	220/1/60	220/1/60	220/1/60	220/1/60
Amperage	(A)	8A	9A	12A	15A
Operating Temperature	°F	+15°F	+15°F	+15°F	+15°F
Net Weights	Kg/Lb	130Kgs / 286Lbs	200Kgs / 440Lbs	240Kgs / 528Lbs	279Kgs / 616Lbs
Crated Weights	Kg/Lb	145Kgs / 319Lbs	220Kgs / 484Lbs	255Kgs / 561Lbs	289Kgs / 638Lbs

* DIMENSIONS ARE WITHOUT SIDE PANELS * REMOTE APPLICATION - CONDENSING UNIT SOLD SEPERATELY * FLOOR SINK RECOMMENDED ON THESE MODELS

CLASSIC GRAB AND GO					
TECHNICAL FEATURES		MODELS			
		CLASSIC GNG 2000	CLASSIC GNG A30	CLASSIC GNG A90	CLASSIC GNG A90X
External Dimensions (L-D-H)	Inches	78 3/4" - 37 5/8" - 52 1/16"	64 11/16" - 37 5/8" - 52 1/16"	65" - 37 5/8" - 52 1/16"	70 13/16" - 37 5/8" - 34 5/8"
	Inches-MM	2000 - 956 - 1322	1643 - 956 - 1322	1651 - 956 - 1322	1798 - 956 - 879
Crated Dimensions (L-D-H)	Inches	84" - 43" - 60"	70" - 43" - 60"	70" - 43" - 60"	77" - 43" - 41"
	Inches-MM	2133 - 1092 - 1524	1778 - 1092 - 1524	1778 - 1092 - 1524	1955 - 1092 - 1041
BTU's @ +14°F Evap Temperature	BTU'S	8820 BTU'S	6720 BTU'S	8950 BTU'S	12,600 BTU'S
Power Supply	(V/Ph/Hz)	220/1/60	220/1/60	220/1/60	220/1/60
Amperage	(A)	16A	15A	17A	2A
Operating Temperature	°F	+15°F	+15°F	+15°F	+15°F
Net Weights	Kg/Lb	300Kgs / 660Lbs	240Kgs / 528Lbs	300Kgs / 660Lbs	344Kgs / 760Lbs
Crated Weights	Kg/Lb	330Kgs / 726Lbs	255Kgs / 561Lbs	330Kgs / 726Lbs	374Kgs / 826Lbs

* DIMENSIONS ARE WITHOUT SIDE PANELS * REMOTE APPLICATION - CONDENSING UNIT SOLD SEPERATELY * FLOOR SINK RECOMMENDED ON THESE MODELS

* Manufacturer reserves the right to change specifications without notice. Not responsible for error and omissions.



361-367 Beach Road, Burlingame, CA 94010
 Tel: 855.885.2400 | 650.342.2400 | Fax: 650.342.7400
 sales@oscartek.com | www.oscartek.com



ELECTRICAL LEGEND	
	1/4" DRAIN
	REFRIGERATION LINES: 3/8" LIQUID, 1/2" SUCTION
	POWER

SECTION VIEW

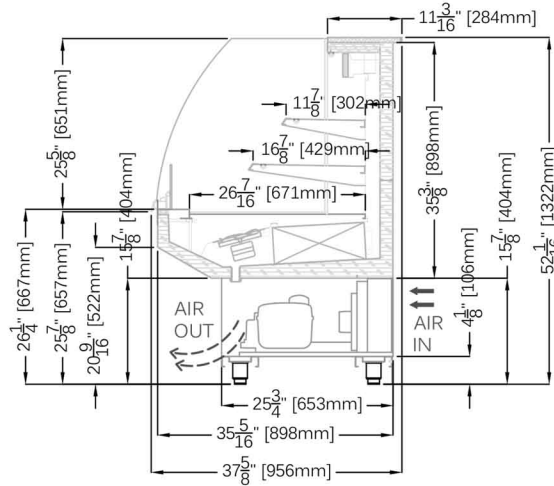

SECTION VIEW GNG A90X

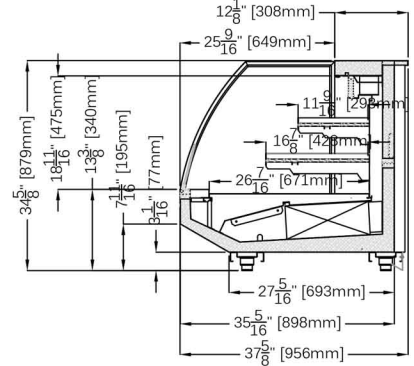

PLAN VIEWS:

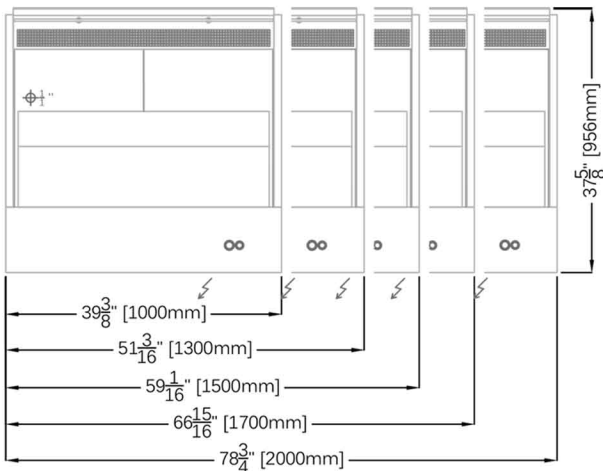

GNG A30

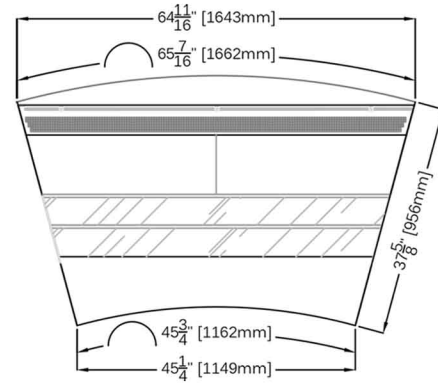

GNG A90

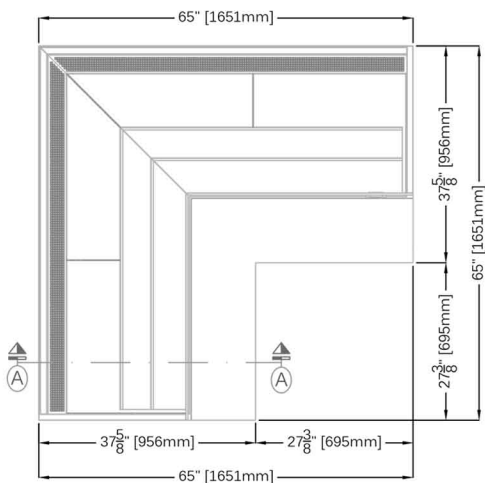

GNG A90X

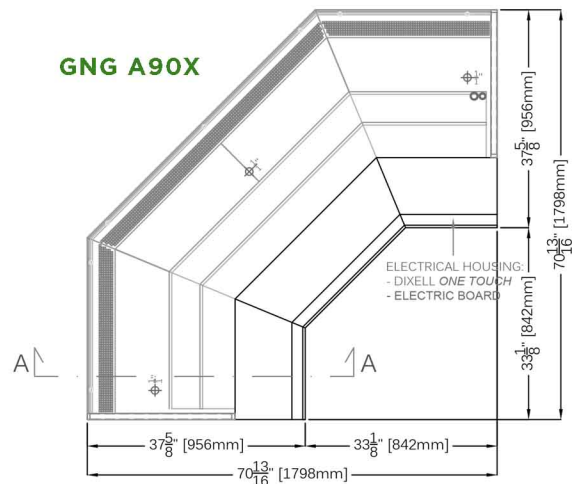

* Manufacturer reserves the right to change specifications without notice. Not responsible for error and omissions.

CLASSIC GNG

Grab and Go Showcase

FRONT ELEVATIONS (CUSTOMER SIDE):

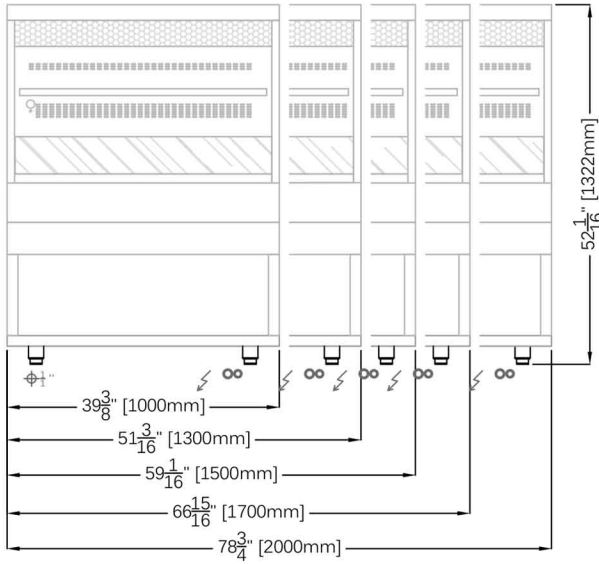

GNG A30

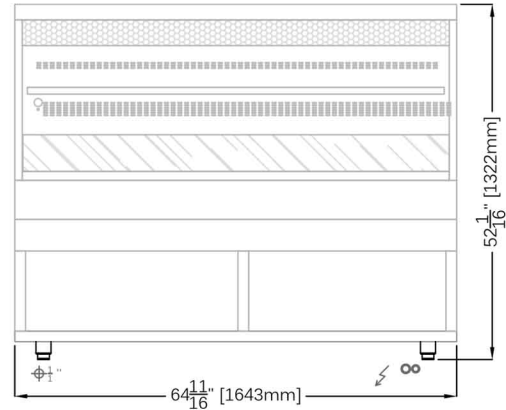

SECTION A-A GNG A90

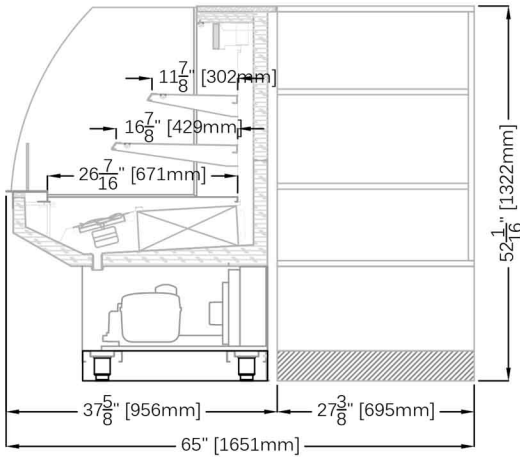

SECTION A-A GNG A90X

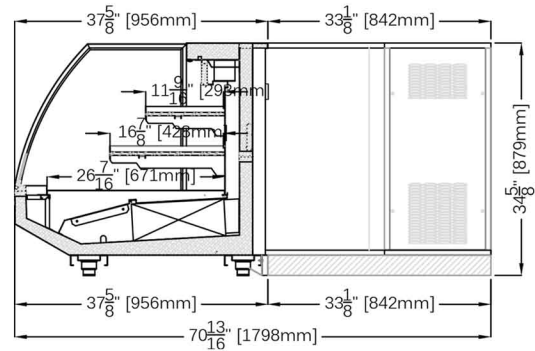

FRONT ELEVATION (CUSTOMER SIDE) GNG A90X

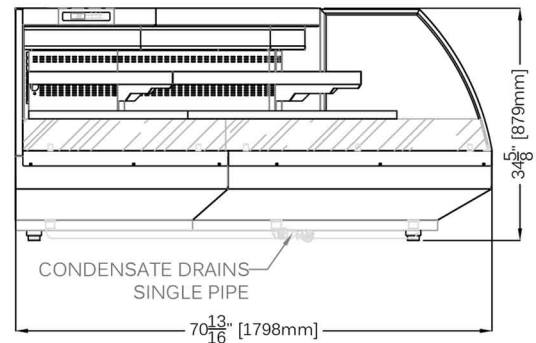

* Manufacturer reserves the right to change specifications without notice. Not responsible for error and omissions.



361-367 Beach Road, Burlingame, CA 94010
Tel: 855.885.2400 | 650.342.2400 | Fax: 650.342.7400
sales@oscartek.com | www.oscartek.com



CLASSIC STATIC

Ice Cream/ Gelato Round Tubs Showcase

TOP GLASS OPTIONS

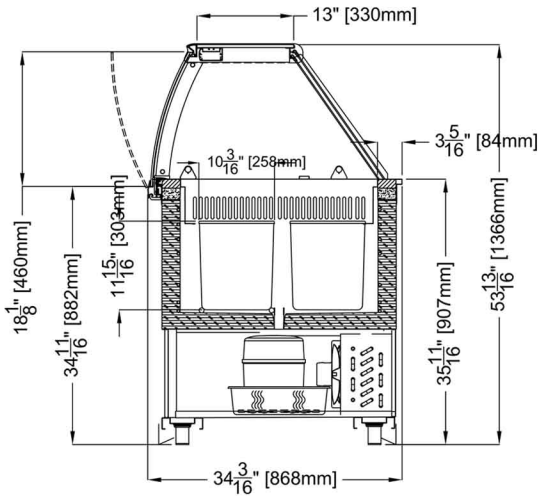
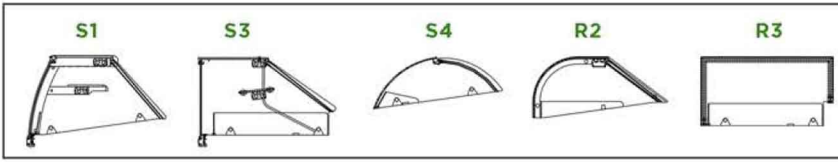

STANDARD FEATURES

- Stainless steel insulated body with tubular painted galvanized chassis
- Silver trim finish
- Dixell digital controller
- Air cooled condensing unit
- Tempered front and side glass single pane with anti-fog serigraph
- Tilt back front glass
- LED lighting
- Plexiglass sliding doors
- Stainless steel work bench
- Cases ship standard unfinished front and stainless steel skin sides



OPTIONS

- Champagne trim finish
- Custom stainless steel deck
- Wheels kit
- Dip well
- Cone holder
- Frozen cake stainless steel trays
- Marble/granite work counter
- RAL color finish/wood laminate
- Roll down curtain
- Remote/self contained water cooled unit
- Matching front cabinetry counters with top glass

CLASSIC STATIC				
TECHNICAL FEATURES		MODELS		
		1000	1500	2000
External Dimensions (L-D-H)	Inches	39 1/2" - 34 3/16" - 53 13/16"	59 1/16" - 34 3/16" - 53 13/16"	78 3/4" - 34 3/16" - 53 13/16"
	Inches-MM	1000 - 868 - 1366	1500 - 868 - 1366	2000 - 868 - 1366
Crated Dimensions (L-D-H)	Inches	44" - 40" - 59"	65" - 40" - 59"	84" - 40" - 59"
	Inches-MM	1117 - 1016 - 1498	1600 - 1016 - 1498	2133 - 1016 - 1498
Number of Round Tubs	#	6	10	14
Power Supply	(V/Hz)	220V/60Hz	220V/60Hz	220V/60Hz
Amperage	(A)	8A	14A	15A
Operating Temperature	°C / °F	-10°F to 0°F	-10°F to 0°F	-10°F to 0°F
Cooling BTU's	BTU'S	2200	2800	3400
Net Weights	Kg/Lb	165Kg / 363Lb	220Kg / 484Lb	274Kg / 602Lb
Crated Weights	Kg/Lb	180Kg / 396Lb	240Kg / 528Lb	298Kg / 655Lb

* Manufacturer reserves the right to change specifications without notice. Not responsible for error and omissions.



361-367 Beach Road, Burlingame, CA 94010
 Tel: 855.885.2400 | 650.342.2400 | Fax: 650.342.7400
 sales@oscartek.com | www.oscartek.com



CLASSIC SQUARE

Deli/Pastry Showcase

DELI/PASTRY WITHOUT DRAWERS

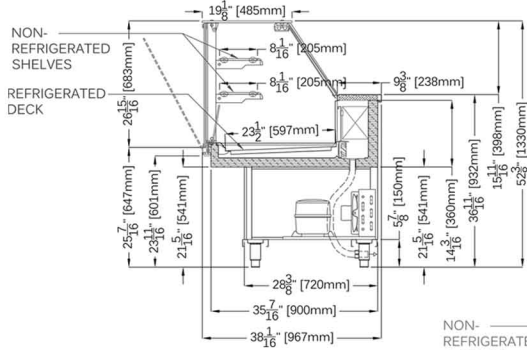

DELI/PASTRY WITH DRAWERS

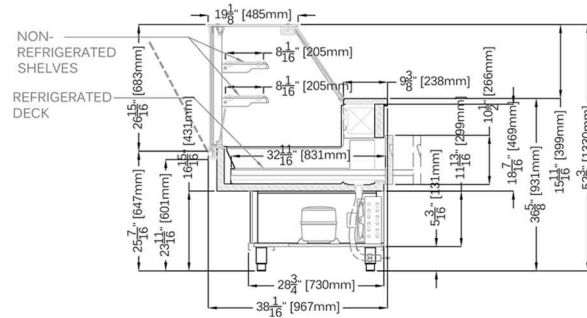

STANDARD FEATURES

- Stainless steel insulated body with tubular painted galvanized chassis
- Silver trim finish
- Dixell digital controller
- Air cooled condensing unit
- Temperature front and side glass single pane with anti-fog serigraph
- Lift up hydraulic front glass
- LED lighting
- Plexiglass sliding doors
- Stainless steel work bench
- Pastry with drawer (static refrigeration)
- Cases ship standard unfinished front and stainless steel skin sides

OPTIONS

- Marble/Granite work counter
- RAL color finish/wood laminate
- Champagne trim finish
- Roll down curtain
- Remote/water cooled unit
- Matching front cabinetry counters with top glass
- Stainless steel step up deck shelf
- Cold storage option with static refrigeration and separate control
- Casters

A90 CURVE

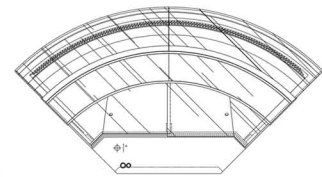

A90 SQUARE - LEFT

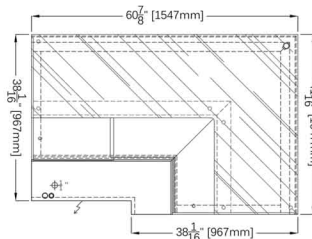

A90 SQUARE - RIGHT

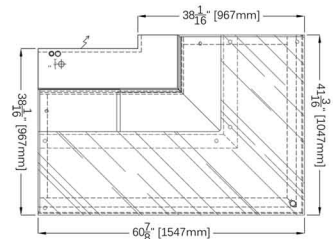

CLASSIC SQUARE DELI/PASTRY

TECHNICAL FEATURES		MODELS						
		CLASSIC SDP1000	CLASSIC SDP1500	CLASSIC SDP2000	CLASSIC SDP2500	CLASSIC SDP3000	CLASSIC SDPA90C	CLASSIC SDPA90SQ
External Dimensions (L-D-H)	Inches	39 1/2" - 38 1/16" - 52 3/8"	59 1/8" - 38 1/16" - 52 3/8"	78 3/4" - 38 1/16" - 52 3/8"	98 1/2" - 38 1/16" - 52 3/8"	118 1/4" - 38 1/16" - 52 3/8"	80 1/16" - 38 1/16" - 52 3/8"	** 41 3/16" - 38 1/16" - 52 3/8"
	Inches-MM	1000 - 967 - 1330	1500 - 967 - 1330	2000 - 967 - 1330	2500 - 967 - 1330	3000 - 967 - 1330	2034 - 967 - 1330	1047 - 967 - 1330
Crated Dimensions (L-D-H)	Inches	44" - 42 1/2" - 57"	65" - 42 1/4" - 57"	84 3/4" - 42 1/4" - 57"	102 3/4" - 42 1/4" - 57"	122 3/4" - 42 1/4" - 57"	86" - 42 1/4" - 57"	47" - 42 1/4" - 57"
	Inches-MM	1100 - 1056 - 1447	1600 - 1056 - 1447	2100 - 1056 - 1447	2600 - 1056 - 1447	3100 - 1056 - 1447	2184 - 1056 - 1447	1193 - 1056 - 1447
Power Supply	(V)	120V	120V	120V	120V	120V	120V	120V
BTU'S @ +14°F Evap	BTU'S	1600 BTU'S	2016 BTU'S	2560 BTU'S	3072 BTU'S	3072 BTU'S	2400 BTU'S	2400 BTU'S
Amperage	(A)	5A	5.5A	8.5A	8.6A	11A	5A	5A
Deck Operating Temperature*	°F	39°F	39°F	39°F	39°F	39°F	39°F	39°F
Net Weights	Kg/Lb	147Kgs / 323Lbs	186Kgs / 410Lbs	224Kgs / 492Lbs	271Kgs / 596Lbs	314Kgs / 722Lbs	186Kgs / 410Lbs	186Kgs / 410Lbs
Crated Weights	Kg/Lb	157Kgs / 297Lbs	200Kgs / 440Lbs	239Kgs / 526Lbs	291Kgs / 640Lbs	334Kb / 734Lbs	200Kgs / 440Lbs	200Kgs / 440Lbs

* DIMENSIONS ARE WITHOUT SIDE PANELS * ANY AND ALL SHELVES ABOVE THE DECK WILL NOT BE REFRIGERATED ON THESE MODELS ** PLEASE SEE PLAN VIEW FOR ADDITIONAL DIMENSIONS

* Manufacturer reserves the right to change specifications without notice. Not responsible for error and omissions.



361-367 Beach Road, Burlingame, CA 94010
 Tel: 855.885.2400 | 650.342.2400 | Fax: 650.342.7400
 sales@oscartek.com | www.oscartek.com

