



Project:

Item:

Quantity:

VACUUM PACKING MACHINE JUMBO 35 - SPEC SHEET

JUMBO 35

VACUUM PACKAGING MACHINE



FEATURES

- Seal bar length: 13.5"
- Seal bar with two wires, for double security
- Seal bar easily removable for cleaning and maintenance purposes
- Pump capacity: 678 cf/h (19 m³/h) Busch vacuum pump
- Pump maintenance and cleaning program
- Machine cycle: 15-30 sec
- Time control: 1-99 sec
- Transparent lid, which opens automatically after every cycle
- Deep drawn vacuum chamber
- Comes with insert plates for a faster cycle and product adjustment
- Stainless steel exterior
- 6ft cord with Nema 5-15P plug

DESCRIPTION

The robust, stainless steel Jumbo 35 vacuum packer is standard equipped with a Busch vacuum pump, is ETL listed and complies with UL, CSA and CE standards.

OPTIONS AND ACCESSORIES

- Cut-off seal
- Wide seal
- Inclined insert plate
- Food container adaptor



WARRANTY

Henkelman Inc offers a warranty of 1 year on labor and 3 years on parts. For full warranty details, please refer to www.henkelman.com.

DATE

APPROVAL



FIT FOR FOOD SERVICE
WWW.HENKELMAN.COM

HENKELMAN INC.
493 W Fullerton Ave
Elmhurst IL, 60126

Sales and technical support
P +1 331 979 2013
F +1 630 359 3875
E info@henkelmanusa.com
Service and warranty
P +1 844 208 5685

VACUUM PACKING MACHINE JUMBO 35 – SPECS

VACUUM PACKING MACHINE JUMBO 35 – SPEC SHEET

DIMENSIONS

In inches

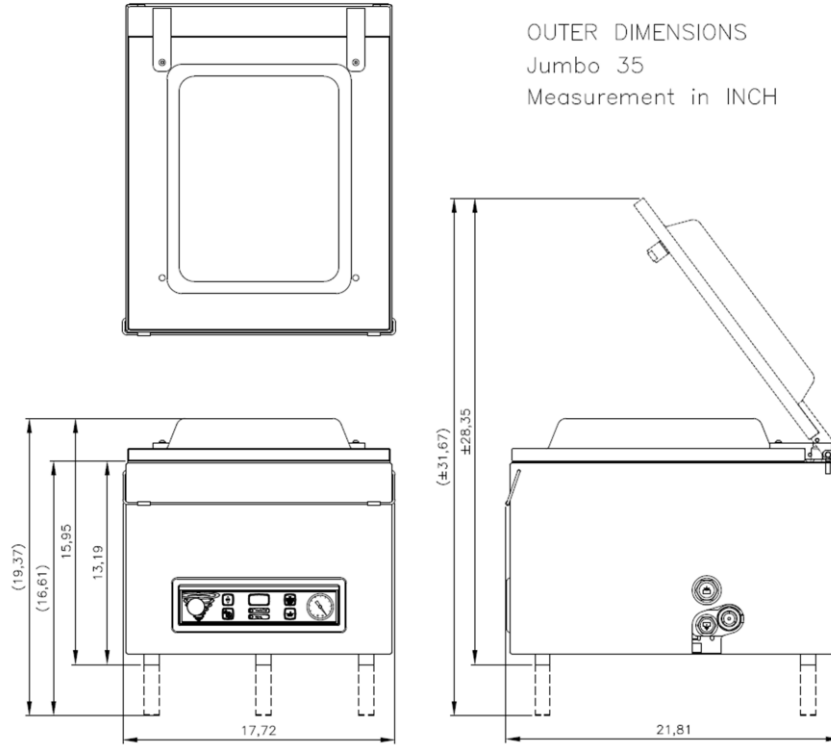

OUTER DIMENSIONS
Jumbo 35
Measurement in INCH

Model	Dimensions (inches)		Volts	Amps	Hz	Pump capacity	HP	Plug	Weight (lbs)
	Chamber (usable space) LxWxH	Machine LxWxH							
Jumbo 35	14.5"x13.5"x6"	21.8"x17.7"x15.9"	110-120V	9	60Hz	678 cf/h (19 m ³ /h)	0.74	NEMA 5-15P	112

NEMA 5-15P



15 A/125 V



FIT FOR FOOD SERVICE
WWW.HENKELMAN.COM

HENKELMAN INC.
493 W Fullerton Ave
Elmhurst IL, 60126

Sales and technical support
P +1 331 979 2013
F +1 630 359 3875
E info@henkelmanusa.com
Service and warranty
P +1 844 208 5685