

# GATES ACCUMULATOR CONVEYOR

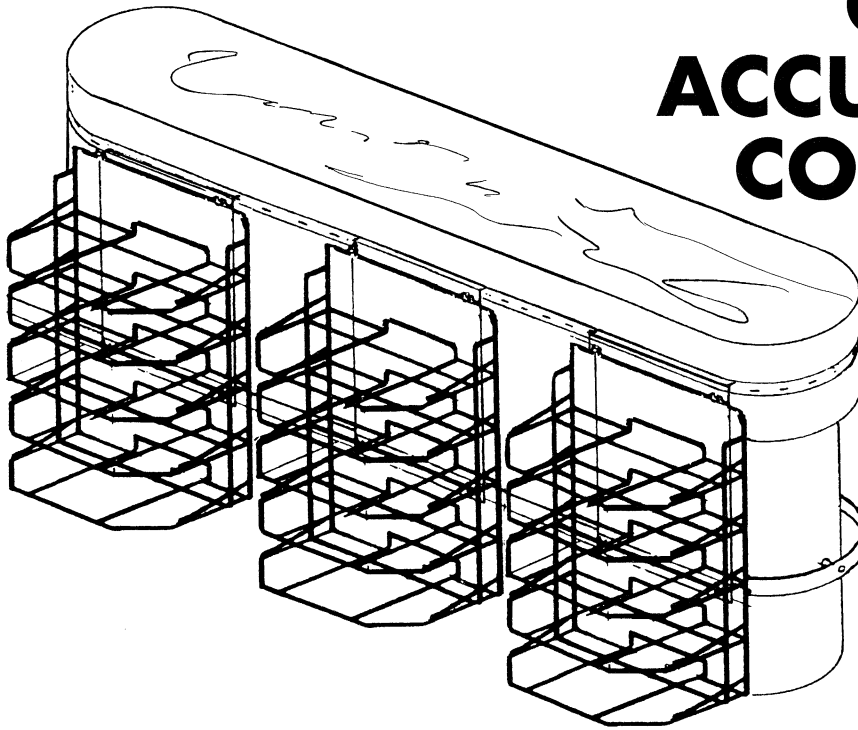

PATENT PENDING

Ideal for Corporate Feeding,  
Schools, Hospitals, Etc. or wherever  
high volume dish return is required  
in a limited area

Available with 5-23 Carriers – 3, 4 or 5 Tier.

See back sheet for layout dimensions and mechanical requirements.

## SPECIFICATIONS

Provide Gates Manufacturing Company U.L. listed Soiled Tray Accumulator System, Model No. SD-SB5-D-6-E-SB.

Conveyor shall be mounted on integral dishtable behind wall opening size and shape per drawing. Overall size of conveyor and tray racks are shown on back of sheet along with tray carrying capacity.

Conveyor shall contain a series of five (5) tiers of S.S. wire racks mounted with side to side dimension of 23" for easy placement of trays with both hands. Tray racks shall be constructed of 1/4" S.S. rod all welded for rigidity. Racks shall be removable by lifting off for cleaning. (narrow tray carriers optional)

Racks shall be mounted on heavy gauge S.S. carriers which are secured to a steel double pitch chain with U.H.M.W.P. rollers for quiet operation. Chain travels through heavy gauge formed steel channel with U.H.M.W.P. wear strips along bottom to prevent wearing of chain. Chain shall continue around drive and idler sprockets and will auto-

matically maintain proper tension at all times through a spring loaded device (pat. pend.). Sprockets are mounted to heavy gauge interior steel framework with self-aligning permanently lubricated bearings.

Conveyor shall be driven by totally enclosed fan cooled D.C. motor through worm gear speed reducer direct connected to drive sprocket. Motor requires 120/1Ø. Motor shall provide electronic variable speed through S.C.R. solid state controller.

Exterior of conveyor drive, intermediate and idler sections constructed of S.S. Interior framework of heavy gauge. All panels shall be removable for access to drive components.

Conveyor shall contain two (2) Photo Eye safety switches mounted at wall openings as required to prevent damage or injury if trays are improperly positioned on carrier. Activation of safety switch will instantaneously shut off conveyor.



**GATES**  
MANUFACTURING

6924 Smiley Avenue  
St. Louis, Missouri, 63139

gatesmfg.com



# GATES ACCUMULATOR CONVEYOR

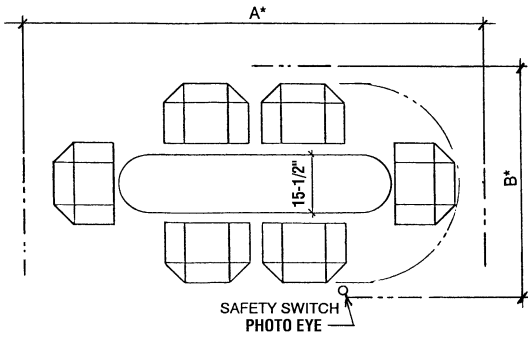

CARRIERS ACCOMMODATES FOLLOWING TRAYS:  
 16" x 22"  
 15" x 20"  
 14" x 18"  
 12" x 16"

FIVE (5) TIER RACK SHOWN

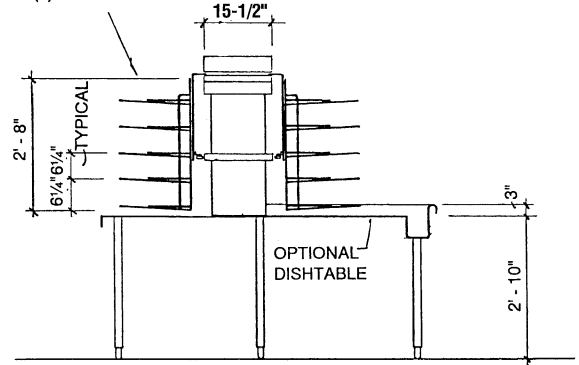

Dimensions shown are minimum inside from face of splash or rim to face of splash or rim. Turn backs must be added on to determine O.A. dimensions.

## STANDARD STYLE

Model No.	No. of Carriers	Max. No. of Trays	(A) Min. Int. Length	(B) Min. Int. Width
SD-SB5-D-5-E-SB	5	25	9'-0-5/8"	5'-2-1/2"
SD-SB5-D-6-E-SB	6	30	10'-2-1/8"	5'-2-1/2"
SD-SB5-D-7-E-SB	7	35	11'-3-5/8"	5'-2-1/2"
SD-SB5-D-8-E-SB	8	40	12'-5-1/8"	5'-2-1/2"
SD-SB5-D-9-E-SB	9	45	13'-6-5/8"	5'-2-1/2"
SD-SB5-D-10-E-SB	10	50	14'-8-1/8"	5'-2-1/2"
SD-SB5-D-11-E-SB	11	55	15'-9-5/8"	5'-2-1/2"
SD-SB5-D-12-E-SB	12	60	16'-11-1/8"	5'-2-1/2"
SD-SB5-D-13-E-SB	13	65	18'-0-5/8"	5'-2-1/2"
SD-SB5-D-14-E-SB	14	70	19'-2-1/8"	5'-2-1/2"
SD-SB5-D-15-E-SB	15	75	20'-3-5/8"	5'-2-1/2"
SD-SB5-D-16-E-SB	16	80	21'-5-1/8"	5'-2-1/2"
SD-SB5-D-17-E-SB	17	85	22'-6-5/8"	5'-2-1/2"
SD-SB5-D-18-E-SB	18	90	23'-8-1/8"	5'-2-1/2"
SD-SB5-D-19-E-SB	19	95	24'-9-5/8"	5'-2-1/2"
SD-SB5-D-20-E-SB	20	100	25'-11-1/8"	5'-2-1/2"

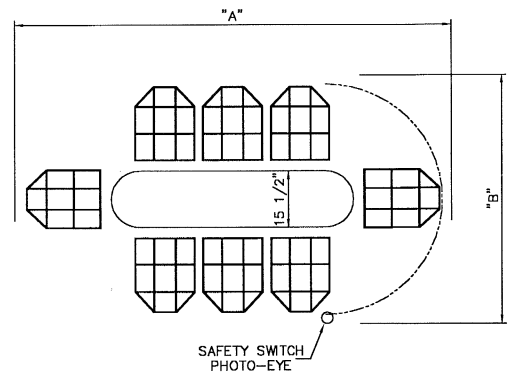

CARRIERS ACCOMMODATES FOLLOWING TRAYS:  
 16" x 22"  
 15" x 20"  
 14" x 18"  
 12" x 16"

## NARROW STYLE

Model No.	No. of Carriers	Max. No. of Trays	(A) Min. Int. Length	(B) Min. Int. Width
(N)SD-SB5-D-8-E-SB	8	40	9'-11-1/8"	5'-8-1/2"
(N)SD-SB5-D-9-E-SB	9	45	10'-8-1/8"	5'-8-1/2"
(N)SD-SB5-D-10-E-SB	10	50	11'-5-1/8"	5'-8-1/2"
(N)SD-SB5-D-11-E-SB	11	55	12'-2-1/8"	5'-8-1/2"
(N)SD-SB5-D-12-E-SB	12	60	12'-11-1/8"	5'-8-1/2"
(N)SD-SB5-D-13-E-SB	13	65	13'-8-1/8"	5'-8-1/2"
(N)SD-SB5-D-14-E-SB	14	70	14'-5-1/8"	5'-8-1/2"
(N)SD-SB5-D-15-E-SB	15	75	15'-2-1/8"	5'-8-1/2"
(N)SD-SB5-D-16-E-SB	16	80	15'-11-1/8"	5'-8-1/2"
(N)SD-SB5-D-17-E-SB	17	85	16'-8-1/8"	5'-8-1/2"
(N)SD-SB5-D-18-E-SB	18	90	17'-5-1/8"	5'-8-1/2"
(N)SD-SB5-D-19-E-SB	19	95	18'-2-1/8"	5'-8-1/2"
(N)SD-SB5-D-20-E-SB	20	100	18'-11-1/8"	5'-8-1/2"
(N)SD-SB5-D-21-E-SB	21	105	19'-8-1/8"	5'-8-1/2"
(N)SD-SB5-D-22-E-SB	22	110	20'-5-1/8"	5'-8-1/2"
(N)SD-SB5-D-23-E-SB	23	115	21'-2-1/8"	5'-8-1/2"

NOTE: Model specifications are subject to change without notice.

Shipped knocked down when possible.

## SECTION

### OPTIONS

- Solid S.S. Carriers w/S.S. Rod Supports
- Laminated Exposed Tray Carrier Bracket
- Painted Tray Carrier Bracket to Match Adjacent Areas
- Narrow Tray Carriers (Either S.S. Rod or Solid) for Maximum Number of Trays
- Choice of Direction
- Five Tier Carriers Standard – any Tier Below Five Available
- Integral Dishtable
- S.S. Pedestal Wall in lieu of Table

### ELECTRICAL INFORMATION

**CONVEYORS MOTOR  
 REQUIRES 120/1Ø  
 20 AMP CIRCUIT**