

STANDARD FEATURES

- Cooking capacity for up to six 12" x 20" x 2.5" deep steam table pans.
- 304 Stainless Steel interior and exterior construction.
- Steam flow directed over each pan from both left and right side of cooking chamber for more even cooking.
- NSF Approved Hold Mode with adjustable thermostat.
- Heavy duty refrigeration style door handle with magnetic latch.
- 60 minute timer with continuous cook and hold mode features.
- UL Listed, NSF Certified and exceeds Energy Star® performance levels.
- Electric heating element not exposed to water and requires no scheduled de-liming.
- No water filtration or treatment required.
- No warranty exclusions for water quality.
- Controls include options for both batch and à la carte cooking modes.
- Bullet feet, 6-foot cord and plug set included.
- One year Parts and Labor Warranty included.

OPTIONS

- Automatic water fill controls; fills when main power is turned ON. Low and High Water probes located inside cooking chamber maintain water level during cooking, eliminating the need to manually maintain water level. Additional High Water Indicating Light and Buzzer included with this option.
- Extended Parts and Labor Warranty up to 5 years.

ACCESSORIES (SOLD SEPARATELY)

- Single unit stand with standard adjustable bullet feet.
- Single unit stand with casters.
- Double unit stand with standard adjustable bullet feet.
- Double unit stand with casters
- 4-inch drain pan (standard 4-inch steam table pan).
- Drain kit (for auto-fill units only).

STERLING STEAMER

6-PAN HIGH EFFICIENCY BOILERLESS CONVECTION STEAMER



SPECIFICATIONS

Single compartment connectionless steamer with capacity for six full-size 2.5-inch or four full-size 4-inch steam table pans. Controls include adjustable hold thermostat with thermometer, 60-minute manual timer with settings for timed or continuous cook and a 2-position switch for batch or à la carte cooking. Dual steam impingement system for directing convection steam evenly over each pan from both sides. Heavy duty 14-gauge cooking compartments and exterior door. Electric heating element mounted underneath chamber with no exposure to mineral or lime buildup. No water quality exclusions to warranty and no water filtration or treatment required. 4-inch adjustable legs included. Power required: 208 or 240VAC, 60Hz, 1 or 3 phase.

Exterior Dimensions: 23"w x 30"d x 30"h.

UL Listed, NSF Certified and exceeds ENERGY STAR® performance levels.



STERLING STEAMER

6-PAN HIGH EFFICIENCY BOILERLESS CONVECTION STEAMER

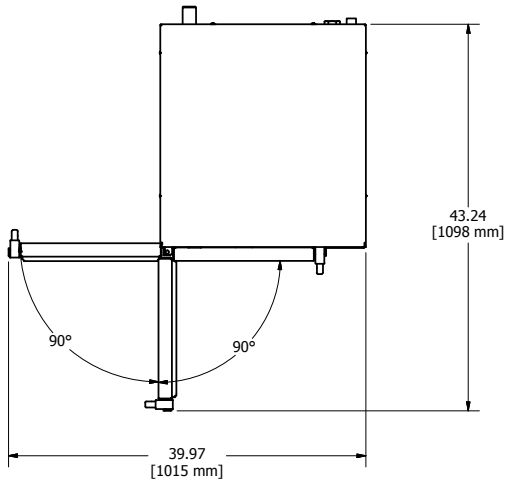

TOP VIEW

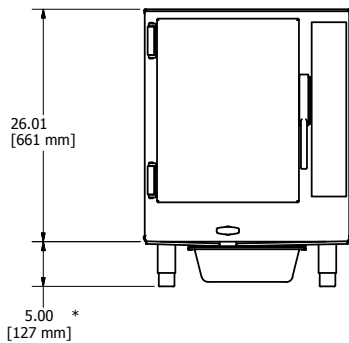

FRONT VIEW

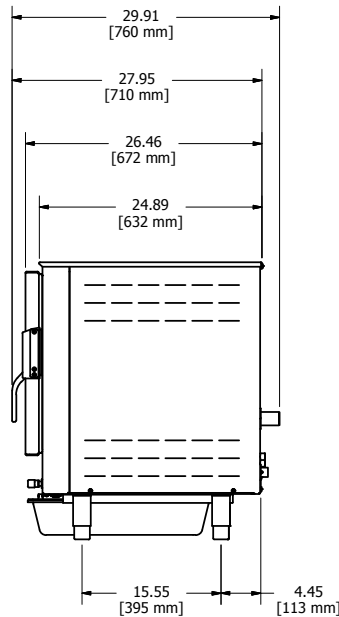

RIGHT SIDE VIEW

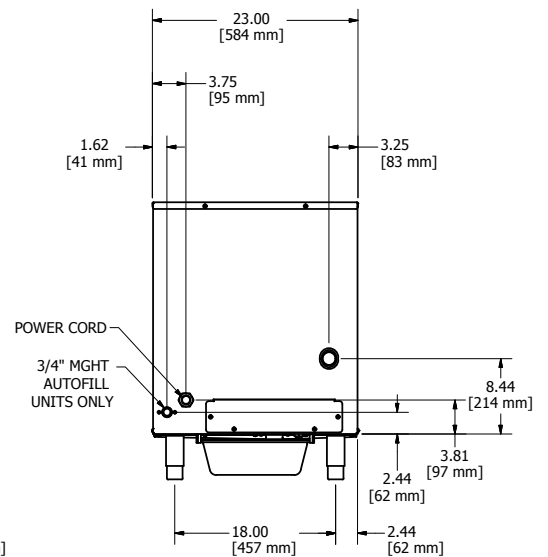

REAR VIEW

* Legs adjust from 4" - 6" (102 - 152mm)

WATER SUPPLY

Feed water for reservoir: 10 - 60 PSI, 32 - 175 ° F, 3/4" MGHT, Use NSF approved hose.

EQUIPMENT CLEARANCE

3" - Left, 3" - Right and 4" - Rear.

CAPACITY

Compartment holds: six 12"x 20"x 2.5" or four 12"x 20"x 4" Steam Table Pans.

NOTE:

- It is the responsibility of the owner and installer to comply with local codes for installation.
- This appliance is manufactured for commercial installation only and is not intended for household use.

Model Number	Volt/Hz/Phase	kW	NEMA Plug	Amps
Sterling Steamer Counter Top, 208V, Electric				
SP208-6-1-AF	208/60/1	6.23	L6-30P	29.95
SP208-10-1-AF	208/60/1	10.0	6-50P	48.08
SP208-10-3-AF	208/60/3	10.0	L15-30P	27.76
SP208-14-3-AF	208/60/3	14.4	15-50P	39.97
Sterling Steamer Counter Top, 240V, Electric				
SP240-6-1-AF	240/60/1	6.23	L6-30P	25.96
SP240-10-1-AF	240/60/1	10.0	6-50P	41.67
SP240-10-3-AF	240/60/3	10.0	L15-30P	24.06
SP240-14-3-AF	240/60/3	14.4	15-50P	34.64

Model Number	Volt/Hz/Phase	kW	NEMA Plug	Amps
Sterling Steamer Counter Top, 208V, Electric				
SP208-6-1-MF	208/60/1	6.23	L6-30P	29.95
SP208-10-1-MF	208/60/1	10.0	6-50P	48.08
SP208-10-3-MF	208/60/3	10.0	L15-30P	27.76
SP208-14-3-MF	208/60/3	14.4	15-50P	39.97
Sterling Steamer Counter Top, 240V, Electric				
SP240-6-1-MF	240/60/1	6.23	L6-30P	25.96
SP240-10-1-MF	240/60/1	10.0	6-50P	41.67
SP240-10-3-MF	240/60/3	10.0	L15-30P	24.06
SP240-14-3-MF	240/60/3	14.4	15-50P	34.64



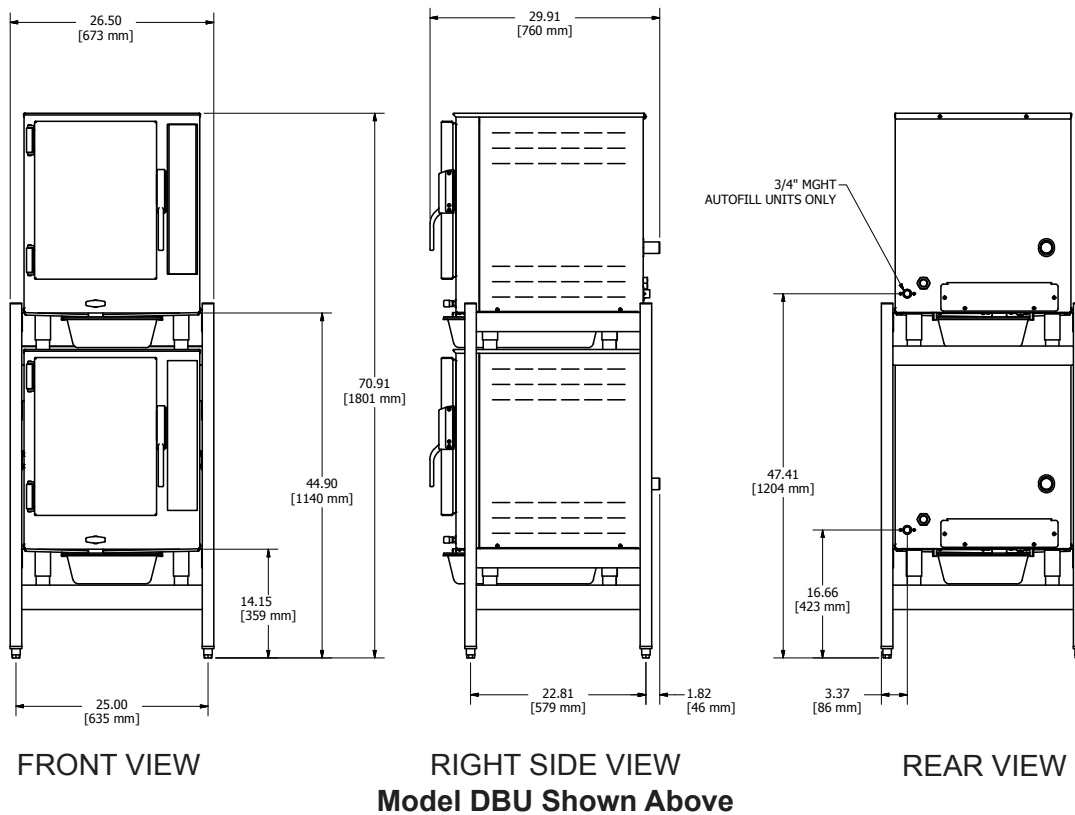
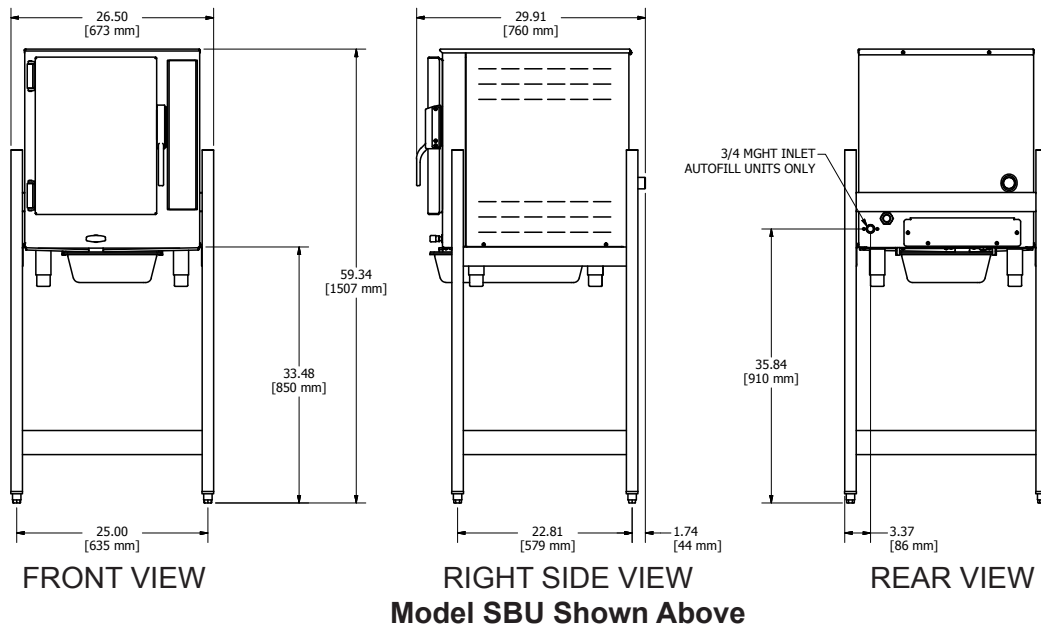

Note: Dimensions do not change for variations in Model Numbers. Bullet Feet and Flanged feet have a 1" adjustment.

Model Number	Steamer Capacity	Style
Sterling Steamer Stand Selector		
SCA	One	5" Caster
SBU	One	Adjustable Bullet Foot
SFL	One	Adjustable Flange Foot

Model Number	Steamer Capacity	Style
Sterling Steamer Stand Selector		
DCA	Two	5" Caster
DBU	Two	Adjustable Bullet Foot
DFL	Two	Adjustable Flange Foot

